



# 210 SERIES LIGHT DUTY FLARED EDGE CLAMP — COATED

## Clip Specifications

**Diameter:** 1/8" - 1 9/16"  
**Bolt Size:** 1/4", 5/16", 3/8"  
**Position:** Furnished Open  
**Coating:** Black Vinyl Plastisol Coating Per SAE J200  
 0.032" Thick ± .015"  
**Notes:** Light duty clip with flared edges for abrasion resistance, one round hole and one slot for ease of alignment, and a developed shape for proper closing.

**Material Code:** A - ASTM A653 CS Type B G90 Galvanized Steel  
 B - ASTM A1008 CS Type B Low Carbon Steel Zinc Plate per ASTM B633 Fe/Zn 8 Type VI Yellow

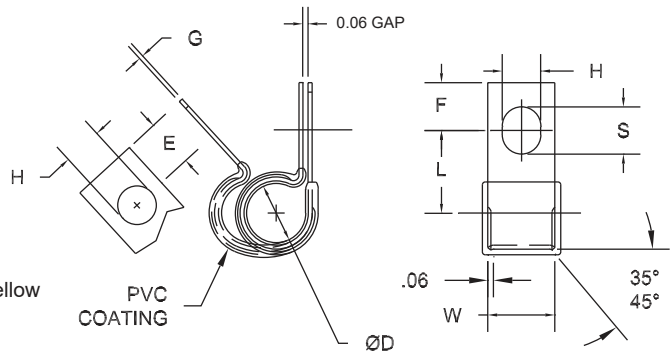

## Part Number Call Out

F213-008 A      Clamp Coated, Galv, 1/2" Dia, 3/8" Bolt  
 Material Code  
 Base Part Number

Base Part Number	D	H	L	W	E	F	G	S
	Clamping Diameter	Hole Diameter	Center to Center	Width	Hole Center to End	Slot Center to End	Material Thickness	Slot Length
	± .015	± .005	± .031	± .010	± .015	± .015	± .002	± .020
F211-002	0.125	0.281	0.468	0.500	0.250	0.296	0.025	0.375
F212-002	0.125	0.343	0.500	0.562	0.281	0.328	0.025	0.437
F213-002	0.125	0.406	0.562	0.625	0.312	0.359	0.025	0.500
F211-003	0.187	0.281	0.500	0.500	0.250	0.296	0.025	0.375
F212-003	0.187	0.343	0.531	0.562	0.281	0.328	0.025	0.437
F213-003	0.187	0.406	0.593	0.625	0.312	0.359	0.025	0.500
F211-004	0.250	0.281	0.531	0.500	0.250	0.296	0.025	0.375
F212-004	0.250	0.343	0.562	0.562	0.281	0.328	0.025	0.437
F213-004	0.250	0.406	0.625	0.625	0.312	0.359	0.025	0.500
F211-005	0.312	0.281	0.562	0.500	0.250	0.296	0.025	0.375
F212-005	0.312	0.343	0.594	0.562	0.281	0.328	0.025	0.437
F213-005	0.312	0.406	0.656	0.625	0.312	0.359	0.025	0.500
F211-006	0.375	0.281	0.593	0.500	0.250	0.296	0.025	0.375
F212-006	0.375	0.343	0.625	0.562	0.281	0.328	0.025	0.437
F213-006	0.375	0.406	0.687	0.625	0.312	0.359	0.025	0.500
F211-007	0.437	0.281	0.625	0.500	0.250	0.296	0.025	0.375
F212-007	0.437	0.343	0.656	0.562	0.281	0.328	0.025	0.437
F213-007	0.437	0.406	0.718	0.625	0.312	0.359	0.025	0.500
F211-008	0.500	0.281	0.656	0.500	0.250	0.296	0.025	0.375
F212-008	0.500	0.343	0.688	0.562	0.281	0.328	0.025	0.437
F213-008	0.500	0.406	0.750	0.625	0.312	0.359	0.025	0.500
F211-009	0.562	0.281	0.687	0.500	0.250	0.296	0.025	0.375
F212-009	0.562	0.343	0.719	0.562	0.281	0.328	0.025	0.437
F213-009	0.562	0.406	0.781	0.625	0.312	0.359	0.025	0.500
F211-010	0.625	0.281	0.718	0.500	0.250	0.296	0.025	0.375
F212-010	0.625	0.343	0.750	0.562	0.281	0.328	0.025	0.437
F213-010	0.625	0.406	0.812	0.625	0.312	0.359	0.025	0.500
F211-011	0.687	0.281	0.750	0.500	0.250	0.296	0.025	0.375
F212-011	0.687	0.343	0.781	0.562	0.281	0.328	0.025	0.437
F213-011	0.687	0.406	0.843	0.625	0.312	0.359	0.025	0.500



**Clip Specifications**

**Diameter:** 1/8" - 1 9/16"  
**Bolt Size:** 1/4", 5/16", 3/8"  
**Position:** Furnished Open  
**Coating:** Black Vinyl Plastisol Coating Per SAE J200  
 0.032" Thick ± .015"  
**Notes:** Light duty clip with flared edges for abrasion resistance, one round hole and one slot for ease of alignment, and a developed shape for proper closing.

**Material Code:** A - ASTM A653 CS Type B G90 Galvanized Steel  
 B - ASTM A1008 CS Type B Low Carbon Steel Zinc Plate per ASTM B633 Fe/Zn 8 Type VI Yellow

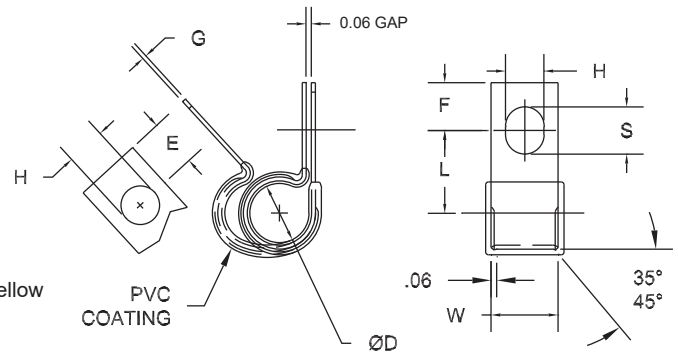

**Part Number Call Out**

F213-008 A Clamp Coated, Galv, 1/2" Dia, 3/8" Bolt  
 Material Code  
 Base Part Number

Base Part Number	D	H	L	W	E	F	G	S
	Clamping Diameter	Hole Diameter	Center to Center	Width	Hole Center to End	Slot Center to End	Material Thickness	Slot Length
	± .015	± .005	± .031	± .010	± .015	± .015	± .002	± .020
F211-012	0.750	0.281	0.781	0.500	0.250	0.296	0.025	0.375
F212-012	0.750	0.343	0.812	0.562	0.281	0.328	0.025	0.437
F213-012	0.750	0.406	0.875	0.625	0.312	0.359	0.025	0.500
F211-013	0.812	0.281	0.812	0.500	0.250	0.296	0.025	0.375
F212-013	0.812	0.343	0.844	0.562	0.281	0.328	0.025	0.437
F213-013	0.812	0.406	0.906	0.625	0.312	0.359	0.025	0.500
F211-014	0.875	0.281	0.843	0.500	0.250	0.296	0.025	0.375
F212-014	0.875	0.343	0.875	0.562	0.281	0.328	0.025	0.437
F213-014	0.875	0.406	0.937	0.625	0.312	0.359	0.025	0.500
F211-015	0.937	0.281	0.875	0.500	0.250	0.296	0.025	0.375
F212-015	0.937	0.343	0.906	0.562	0.281	0.328	0.025	0.437
F213-015	0.937	0.406	0.968	0.625	0.312	0.359	0.025	0.500
F211-016	1.000	0.281	0.906	0.500	0.250	0.296	0.025	0.375
F212-016	1.000	0.343	0.938	0.562	0.281	0.328	0.025	0.437
F213-016	1.000	0.406	1.000	0.625	0.312	0.359	0.025	0.500
F212-018	1.125	0.343	1.000	0.562	0.281	0.328	0.025	0.437
F212-020	1.250	0.343	1.062	0.562	0.281	0.328	0.025	0.437
F212-023	1.438	0.343	1.156	0.562	0.281	0.328	0.025	0.437
F212-025	1.562	0.343	1.219	0.562	0.281	0.328	0.025	0.437



## Warranty Disclaimer

The parts described herein are manufactured as set forth in the specifications listed for each part. Although we have taken reasonable efforts to include accurate and up to date information in this catalog, we make no warranty or representations as to its accuracy. We assume no liability or responsibility for any errors or omissions in the content of the catalog.

Every part listed in the catalog is provided to you "AS IS" WITHOUT WARRANTY OF ANY KIND, EITHER EXPRESS OR IMPLIED, INCLUDING, BUT NOT LIMITED TO, THE IMPLIED WARRANTIES OF MERCHANTABILITY, FITNESS FOR A PARTICULAR PURPOSE, OR NON-INFRINGEMENT.

THIS DISCLAIMER OF LIABILITY APPLIES TO ANY DAMAGES OR INJURY CAUSED BY ANY FAILURE OF PERFORMANCE, ERROR, OMISSION, INTERRUPTION, DELETION, DELAY IN OPERATION OR TRANSMISSION, COMMUNICATION LINE FAILURE, THEFT OR DESTRUCTION OR UNAUTHORIZED ACCESS TO, ALTERATION OF, OR USE OF RECORD, WHETHER FOR BREACH OF CONTRACT, TORTIOUS BEHAVIOR, NEGLIGENCE, OR UNDER ANY OTHER CAUSE OF ACTION. YOU ALSO SPECIFICALLY ACKNOWLEDGE AND AGREE THAT WE ARE NOT LIABLE FOR THE DEFAMATORY, OFFENSIVE OR ILLEGAL CONDUCT OF OTHER PERSONS AND THAT THE RISK OF INJURY FROM THE FOREGOING RESTS ENTIRELY WITH YOU.



**FRANKLIN  
FASTENER**

12701 Beech Daly Road  
Redford, MI 48239-2456  
U.S.A.

TEL 313-537-8900

FAX 313-537-0286

[www.franklinfastener.com](http://www.franklinfastener.com)