



# 420 SERIES DOUBLE TUBE CLAMP — PLAIN

## Clip Specifications

**Diameter:** 3/16" - 1"  
**Bolt Size:** #10 - 1/2"  
**Position:** Furnished Open  
**Notes:** A clip that is designed to be slipped over two tubes or wires of the same diameter and closed with a bolt at assembly, one round hole and one slot for ease of alignment, and a developed shape for proper closing.

**Material Code:** A - ASTM A653 CS Type B G90 Galvanized Steel  
 B - ASTM A1008 CS Type B Low Carbon Steel Zinc Plate per ASTM B633 Fe/Zn 8 Type VI Yellow  
 C - SAE 301/304 Stainless Steel

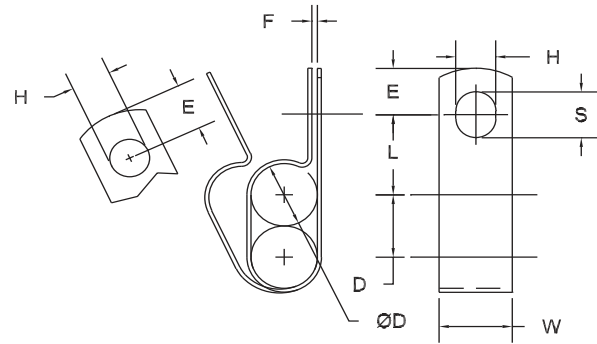

## Part Number Call Out

F423-008 A      Clamp Double Tube Plain, Galv, 1/2" Dia, 5/16" Bolt  
 ———— Material Code  
 ———— Base Part Number

*Different sizes, materials, and/or finishes not shown can be manufactured to meet your specifications*

Base Part Number	D	H	L	W	E	F	G	S
	Clamping Diameter	Hole Diameter	Center to Center	Width	Hole/Slot Center to End	Gap	Material Thickness	Slot Length
	± .015	± .005	± .031	± .010	± .015	± .032	± .002	± .020
F421-003	0.187	0.203	0.437	0.500	0.218	0.031	0.032	0.203
F422-003	0.187	0.281	0.468	0.500	0.312	0.031	0.032	0.375
F423-003	0.187	0.343	0.531	0.625	0.375	0.031	0.032	0.437
F424-003	0.187	0.406	0.593	0.750	0.437	0.031	0.032	0.500
F421-004	0.250	0.203	0.468	0.500	0.218	0.031	0.032	0.203
F422-004	0.250	0.281	0.500	0.500	0.312	0.031	0.032	0.375
F423-004	0.250	0.343	0.562	0.625	0.375	0.031	0.032	0.437
F424-004	0.250	0.406	0.625	0.750	0.437	0.031	0.032	0.500
F422-005	0.312	0.281	0.531	0.500	0.312	0.031	0.032	0.375
F423-005	0.312	0.343	0.593	0.625	0.375	0.031	0.032	0.437
F424-005	0.312	0.406	0.656	0.750	0.437	0.031	0.032	0.500
F422-006	0.375	0.281	0.562	0.500	0.312	0.062	0.032	0.375
F423-006	0.375	0.343	0.625	0.625	0.375	0.062	0.032	0.437
F424-006	0.375	0.406	0.687	0.750	0.437	0.062	0.032	0.500
F425-006	0.375	0.468	0.750	0.875	0.500	0.062	0.032	0.562
F425-006	0.375	0.531	0.812	1.000	0.562	0.062	0.032	0.625
F422-007	0.437	0.281	0.593	0.500	0.312	0.062	0.032	0.375
F423-007	0.437	0.343	0.656	0.625	0.375	0.062	0.032	0.437
F424-007	0.437	0.406	0.718	0.750	0.437	0.062	0.032	0.500
F425-007	0.437	0.468	0.781	0.875	0.500	0.062	0.032	0.562
F426-007	0.437	0.531	0.843	1.000	0.562	0.062	0.048	0.625
F422-008	0.500	0.281	0.625	0.500	0.312	0.062	0.048	0.375
F423-008	0.500	0.343	0.687	0.625	0.375	0.062	0.048	0.437
F424-008	0.500	0.406	0.750	0.750	0.437	0.062	0.048	0.500
F425-008	0.500	0.468	0.812	0.875	0.500	0.062	0.048	0.562
F426-008	0.500	0.531	0.875	1.000	0.562	0.062	0.048	0.625
F422-009	0.562	0.281	0.656	0.500	0.312	0.062	0.048	0.375
F423-009	0.562	0.343	0.718	0.625	0.375	0.062	0.048	0.437
F424-009	0.562	0.406	0.781	0.750	0.437	0.062	0.048	0.500
F425-009	0.562	0.468	0.843	0.875	0.500	0.062	0.048	0.562



**Clip Specifications**

**Diameter:** 3/16" - 1"  
**Bolt Size:** #10 - 1/2"  
**Position:** Furnished Open  
**Notes:** A clip that is designed to be slipped over two tubes or wires of the same diameter and closed with a bolt at assembly, one round hole and one slot for ease of alignment, and a developed shape for proper closing.

**Material Code:** A - ASTM A653 CS Type B G90 Galvanized Steel  
 B - ASTM A1008 CS Type B Low Carbon Steel Zinc Plate per ASTM B633 Fe/Zn 8 Type VI Yellow  
 C - SAE 301/304 Stainless Steel

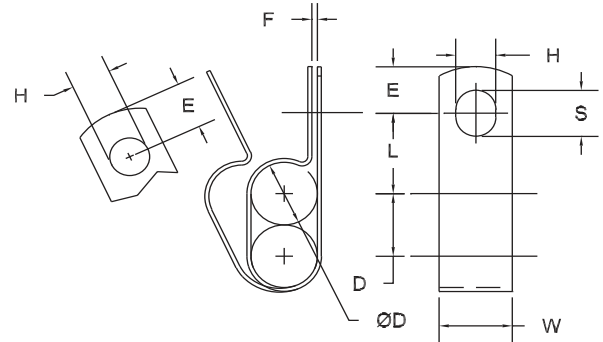

**Part Number Call Out**

F423-008 A Clamp Double Tube Plain, Galv, 1/2" Dia, 5/16" Bolt  
 Material Code  
 Base Part Number

*Different sizes, materials, and/or finishes not shown can be manufactured to meet your specifications*

Base Part Number	D	H	L	W	E	F	G	S
	Clamping Diameter	Hole Diameter	Center to Center	Width	Hole/Slot Center to End	Gap	Material Thickness	Slot Length
	± .015	± .005	± .031	± .010	± .015	± .032	± .002	± .020
F426-009	0.562	0.531	0.906	1.000	0.562	0.062	0.048	0.625
F422-010	0.625	0.281	0.718	0.500	0.312	0.062	0.048	0.375
F423-010	0.625	0.343	0.750	0.625	0.375	0.062	0.048	0.437
F424-010	0.625	0.406	0.812	0.750	0.437	0.062	0.048	0.500
F425-010	0.625	0.468	0.875	0.875	0.500	0.062	0.048	0.562
F426-010	0.625	0.531	0.937	1.000	0.562	0.062	0.048	0.625
F423-011	0.687	0.343	0.781	0.625	0.375	0.062	0.048	0.437
F424-011	0.687	0.406	0.843	0.750	0.437	0.062	0.048	0.500
F425-011	0.687	0.468	0.906	0.875	0.500	0.062	0.048	0.562
F426-011	0.687	0.531	0.968	1.000	0.562	0.062	0.048	0.625
F423-012	0.750	0.343	0.812	0.625	0.375	0.062	0.048	0.437
F424-012	0.750	0.406	0.875	0.750	0.437	0.062	0.048	0.500
F425-012	0.750	0.468	0.937	0.875	0.500	0.062	0.048	0.562
F426-012	0.750	0.531	1.000	1.000	0.562	0.062	0.048	0.625
F423-013	0.812	0.343	0.843	0.625	0.375	0.062	0.060	0.437
F424-013	0.812	0.406	0.906	0.750	0.437	0.062	0.060	0.500
F425-013	0.812	0.468	0.968	0.875	0.500	0.062	0.060	0.562
F426-013	0.812	0.531	1.031	1.000	0.562	0.062	0.060	0.625
F423-014	0.875	0.343	0.875	0.625	0.375	0.062	0.060	0.437
F424-014	0.875	0.406	0.937	0.750	0.437	0.062	0.060	0.500
F425-014	0.875	0.468	1.000	0.875	0.500	0.062	0.060	0.562
F426-014	0.875	0.531	1.062	1.000	0.562	0.062	0.060	0.625
F423-015	0.937	0.343	0.906	0.625	0.375	0.062	0.060	0.437
F424-015	0.937	0.406	0.968	0.750	0.437	0.062	0.060	0.500
F425-015	0.937	0.468	1.031	0.875	0.500	0.062	0.060	0.562
F426-015	0.937	0.531	1.093	1.000	0.562	0.062	0.060	0.625
F423-016	1.000	0.343	0.937	0.625	0.375	0.062	0.060	0.437
F424-016	1.000	0.406	1.000	0.750	0.437	0.062	0.060	0.500
F425-016	1.000	0.468	1.062	0.875	0.500	0.062	0.060	0.562
F426-016	1.000	0.531	1.125	1.000	0.562	0.062	0.060	0.625



## Warranty Disclaimer

The parts described herein are manufactured as set forth in the specifications listed for each part. Although we have taken reasonable efforts to include accurate and up to date information in this catalog, we make no warranty or representations as to its accuracy. We assume no liability or responsibility for any errors or omissions in the content of the catalog.

Every part listed in the catalog is provided to you "AS IS" WITHOUT WARRANTY OF ANY KIND, EITHER EXPRESS OR IMPLIED, INCLUDING, BUT NOT LIMITED TO, THE IMPLIED WARRANTIES OF MERCHANTABILITY, FITNESS FOR A PARTICULAR PURPOSE, OR NON-INFRINGEMENT.

THIS DISCLAIMER OF LIABILITY APPLIES TO ANY DAMAGES OR INJURY CAUSED BY ANY FAILURE OF PERFORMANCE, ERROR, OMISSION, INTERRUPTION, DELETION, DELAY IN OPERATION OR TRANSMISSION, COMMUNICATION LINE FAILURE, THEFT OR DESTRUCTION OR UNAUTHORIZED ACCESS TO, ALTERATION OF, OR USE OF RECORD, WHETHER FOR BREACH OF CONTRACT, TORTIOUS BEHAVIOR, NEGLIGENCE, OR UNDER ANY OTHER CAUSE OF ACTION. YOU ALSO SPECIFICALLY ACKNOWLEDGE AND AGREE THAT WE ARE NOT LIABLE FOR THE DEFAMATORY, OFFENSIVE OR ILLEGAL CONDUCT OF OTHER PERSONS AND THAT THE RISK OF INJURY FROM THE FOREGOING RESTS ENTIRELY WITH YOU.



# FRANKLIN FASTENER

12701 Beech Daly Road  
Redford, MI 48239-2456  
U.S.A.

TEL 313-537-8900

FAX 313-537-0286

[www.franklinfastener.com](http://www.franklinfastener.com)