



430 SERIES DOUBLE TUBE CLAMP — COATED

Clip Specifications

Diameter: 3/16" - 1"
Bolt Size: #10 - 1/2"
Position: Furnished Open
Coating: Black Vinyl Plastisol Coating Per SAE J200
 0.032" Thick ± .015"
Notes: A clip that is designed to be slipped over two tubes or wires of the same diameter and closed with a bolt at assembly, one round hole and one slot for ease of alignment, and a developed shape for proper closing.

Material Code: A - ASTM A653 CS Type B G90
 Galvanized Steel
 B - ASTM A1008 CS Type B Low Carbon Steel
 Zinc Plate per ASTM B633 Fe/Zn 8 Type VI Yellow

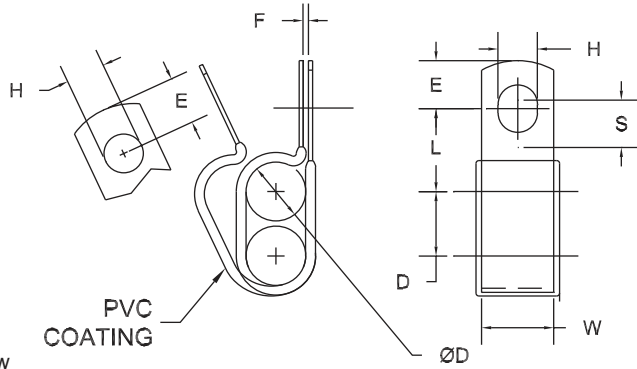

Part Number Call Out

F433-008 A Clamp Double Tube Coated, Galv, 1/2" Dia, 5/16" Bolt
 Material Code
 Base Part Number

Different sizes, materials, and/or finishes not shown can be manufactured to meet your specifications

Base Part Number	D	H	L	W	E	F	G	S
	Clamping Diameter	Hole Diameter	Center to Center	Width	Hole/Slot Center to End	Gap	Material Thickness	Slot Length
	± .015	± .005	± .031	± .010	± .015	± .032	± .002	± .020
F431-003	0.187	0.203	0.437	0.500	0.218	0.031	0.032	0.203
F432-003	0.187	0.281	0.468	0.500	0.312	0.031	0.032	0.375
F433-003	0.187	0.343	0.531	0.625	0.375	0.031	0.032	0.437
F434-003	0.187	0.406	0.593	0.750	0.437	0.031	0.032	0.500
F431-004	0.250	0.203	0.468	0.500	0.218	0.031	0.032	0.203
F432-004	0.250	0.281	0.500	0.500	0.312	0.031	0.032	0.375
F433-004	0.250	0.343	0.562	0.625	0.375	0.031	0.032	0.437
F434-004	0.250	0.406	0.625	0.750	0.437	0.031	0.032	0.500
F432-005	0.312	0.281	0.531	0.500	0.312	0.031	0.032	0.375
F433-005	0.312	0.343	0.593	0.625	0.375	0.031	0.032	0.437
F434-005	0.312	0.406	0.656	0.750	0.437	0.031	0.032	0.500
F432-006	0.375	0.281	0.562	0.500	0.312	0.062	0.032	0.375
F433-006	0.375	0.343	0.625	0.625	0.375	0.062	0.032	0.437
F434-006	0.375	0.406	0.687	0.750	0.437	0.062	0.032	0.500
F435-006	0.375	0.468	0.750	0.875	0.500	0.062	0.032	0.562
F436-006	0.375	0.531	0.812	1.000	0.562	0.062	0.032	0.625
F432-007	0.437	0.281	0.593	0.500	0.312	0.062	0.032	0.375
F433-007	0.437	0.343	0.656	0.625	0.375	0.062	0.032	0.437
F434-007	0.437	0.406	0.718	0.750	0.437	0.062	0.032	0.500
F435-007	0.437	0.468	0.781	0.875	0.500	0.062	0.032	0.562
F436-007	0.437	0.531	0.843	1.000	0.562	0.062	0.048	0.625
F432-008	0.500	0.281	0.625	0.500	0.312	0.062	0.048	0.375
F433-008	0.500	0.343	0.687	0.625	0.375	0.062	0.048	0.437
F434-008	0.500	0.406	0.750	0.750	0.437	0.062	0.048	0.500
F435-008	0.500	0.468	0.812	0.875	0.500	0.062	0.048	0.562
F436-008	0.500	0.531	0.875	1.000	0.562	0.062	0.048	0.625
F432-009	0.562	0.281	0.656	0.500	0.312	0.062	0.048	0.375
F433-009	0.562	0.343	0.718	0.625	0.375	0.062	0.048	0.437
F434-009	0.562	0.406	0.781	0.750	0.437	0.062	0.048	0.500
F435-009	0.562	0.468	0.843	0.875	0.500	0.062	0.048	0.562



Clip Specifications

Diameter: 3/16" - 1"
Bolt Size: #10 - 1/2"
Position: Furnished Open
Coating: Black Vinyl Plastisol Coating Per SAE J200
 0.032" Thick ± .015"
Notes: A clip that is designed to be slipped over two tubes or wires of the same diameter and closed with a bolt at assembly, one round hole and one slot for ease of alignment, and a developed shape for proper closing.

Material Code: A - ASTM A653 CS Type B G90
 Galvanized Steel
 B - ASTM A1008 CS Type B Low Carbon Steel
 Zinc Plate per ASTM B633 Fe/Zn 8 Type VI Yellow

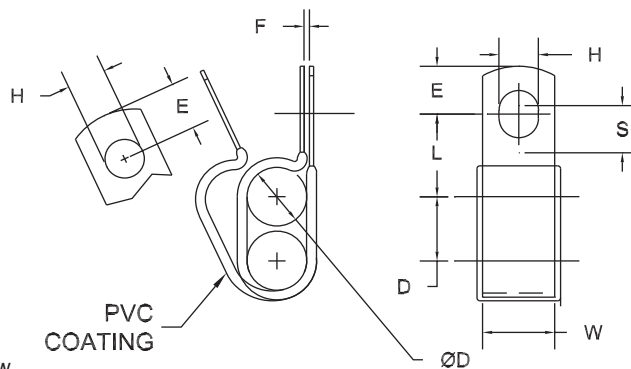

Part Number Call Out

F433-008 A Clamp Double Tube Coated, Galv, 1/2" Dia, 5/16" Bolt
 Material Code
 Base Part Number

Different sizes, materials, and/or finishes not shown can be manufactured to meet your specifications

Base Part Number	D	H	L	W	E	F	G	S
	Clamping Diameter	Hole Diameter	Center to Center	Width	Hole/Slot Center to End	Gap	Material Thickness	Slot Length
	± .015	± .005	± .031	± .010	± .015	± .032	± .002	± .020
F436-009	0.562	0.531	0.906	1.000	0.562	0.062	0.048	0.625
F432-010	0.625	0.281	0.718	0.500	0.312	0.062	0.048	0.375
F433-010	0.625	0.343	0.750	0.625	0.375	0.062	0.048	0.437
F434-010	0.625	0.406	0.812	0.750	0.437	0.062	0.048	0.500
F435-010	0.625	0.468	0.875	0.875	0.500	0.062	0.048	0.562
F436-010	0.625	0.531	0.937	1.000	0.562	0.062	0.048	0.625
F433-011	0.687	0.343	0.781	0.625	0.375	0.062	0.048	0.437
F434-011	0.687	0.406	0.843	0.750	0.437	0.062	0.048	0.500
F435-011	0.687	0.468	0.906	0.875	0.500	0.062	0.048	0.562
F436-011	0.687	0.531	0.968	1.000	0.562	0.062	0.048	0.625
F433-012	0.750	0.343	0.812	0.625	0.375	0.062	0.048	0.437
F434-012	0.750	0.406	0.875	0.750	0.437	0.062	0.048	0.500
F435-012	0.750	0.468	0.937	0.875	0.500	0.062	0.048	0.562
F436-012	0.750	0.531	1.000	1.000	0.562	0.062	0.048	0.625
F433-013	0.812	0.343	0.843	0.625	0.375	0.062	0.060	0.437
F434-013	0.812	0.406	0.906	0.750	0.437	0.062	0.060	0.500
F435-013	0.812	0.468	0.968	0.875	0.500	0.062	0.060	0.562
F436-013	0.812	0.531	1.031	1.000	0.562	0.062	0.060	0.625
F433-014	0.875	0.343	0.875	0.625	0.375	0.062	0.060	0.437
F434-014	0.875	0.406	0.937	0.750	0.437	0.062	0.060	0.500
F435-014	0.875	0.468	1.000	0.875	0.500	0.062	0.060	0.562
F436-014	0.875	0.531	1.062	1.000	0.562	0.062	0.060	0.625
F433-015	0.937	0.343	0.906	0.625	0.375	0.062	0.060	0.437
F434-015	0.937	0.406	0.968	0.750	0.437	0.062	0.060	0.500
F435-015	0.937	0.468	1.031	0.875	0.500	0.062	0.060	0.562
F436-015	0.937	0.531	1.093	1.000	0.562	0.062	0.060	0.625
F433-016	1.000	0.343	0.937	0.625	0.375	0.062	0.060	0.437
F434-016	1.000	0.406	1.000	0.750	0.437	0.062	0.060	0.500
F435-016	1.000	0.468	1.062	0.875	0.500	0.062	0.060	0.562
F436-016	1.000	0.531	1.125	1.000	0.562	0.062	0.060	0.625